

SPECIFICATION

Product Name: Infrared LED Particle Sensor Module

Item No.: PM1003

Version: V0.2

Date: December 29, 2018

Writer	Audit	Approved
Mei Yang		

Revision

No.	Version	Content	Reviser	Date
1	V0.2	The information of the Mating Female Connector and the Connection cable is updated.	Mei Yang	12.29

Infrared (LED) Particle Sensor Module

PM1003



Applications

- Air purifier
- Air quality monitor
- Air conditioner
- Ventilation system
- Consumer electronic products
- Environmental monitoring

Description

PM1003 is an infrared LED particle sensor module, designed to detect the variation trend of particle concentration size between $1.0\mu\text{m}$ ~ $10\mu\text{m}$ with adopting the principle of optical scattering principle. There is an infrared light-emitting diode and an optoelectronic sensor built-in PM1003, and light rays from the light-emitting diode will be reflected when passing through the particle. It can show the dust concentration in the air by detecting the intensity of reflected light. Sensor can output measuring value by PWM or UART signal.

Features

- Particle measured size range: $1.0\mu\text{m}$ ~ $10\mu\text{m}$
- Built-in MCU, directly output particle mass concentration ($\mu\text{g}/\text{m}^3$)
- PWM (pulse width modulation) output (low pulse output)
- The Low pulse width is proportion to particle size and concentration
- Electromagnetic shielding, anti-interference
- High stability and good consistency
- Signal output optional: PWM, UART
- Temperature compensation within whole measurement range

Working Principle

According to the scattering principle of light, the LED light generates reflected light when meet particles. Reflected light will be detected by photosensitive components. Photosensitive components will output high level when do not detect particles. Otherwise, output low pulse when detect particles. And pulse signal is in proportion on the detected light intensity. Pulse signal will be magnified by amplifier and calculated by MCU, output measuring result finally.

Specifications

LED Particle Sensor Specification

Operating principle	Light scattering
Measured particle range	1.0 μm ~ 10 μm
Measurement range	0~500 $\mu\text{g}/\text{m}^3$
Resolution	1 $\mu\text{g}/\text{m}^3$
Working condition	-10°C ~ 50°C, 0-95%RH (non-condensing)
Storage condition	-20°C ~60°C, 0-95%RH (non-condensing)
PM2.5 Measurement accuracy	0~100 $\mu\text{g}/\text{m}^3$: $\pm 30\mu\text{g}/\text{m}^3$ 100~500 $\mu\text{g}/\text{m}^3$, $\pm 30\%$ of reading Condition: 25 $\pm 2^\circ\text{C}$, 50 $\pm 10\%$ RH
Data refresh frequency	1sec
Time to first reading	≤ 30 seconds
Power supply	DC 5V $\pm 0.25\text{V}$, ripple wave <50 mV
Working current	≤ 90 mA
Dimensions	59 \times 45 \times 17.2 mm
Digital output 1	UART_TTL
Digital output 2	PWM
MTTF	>7 years

Internal Architecture Description

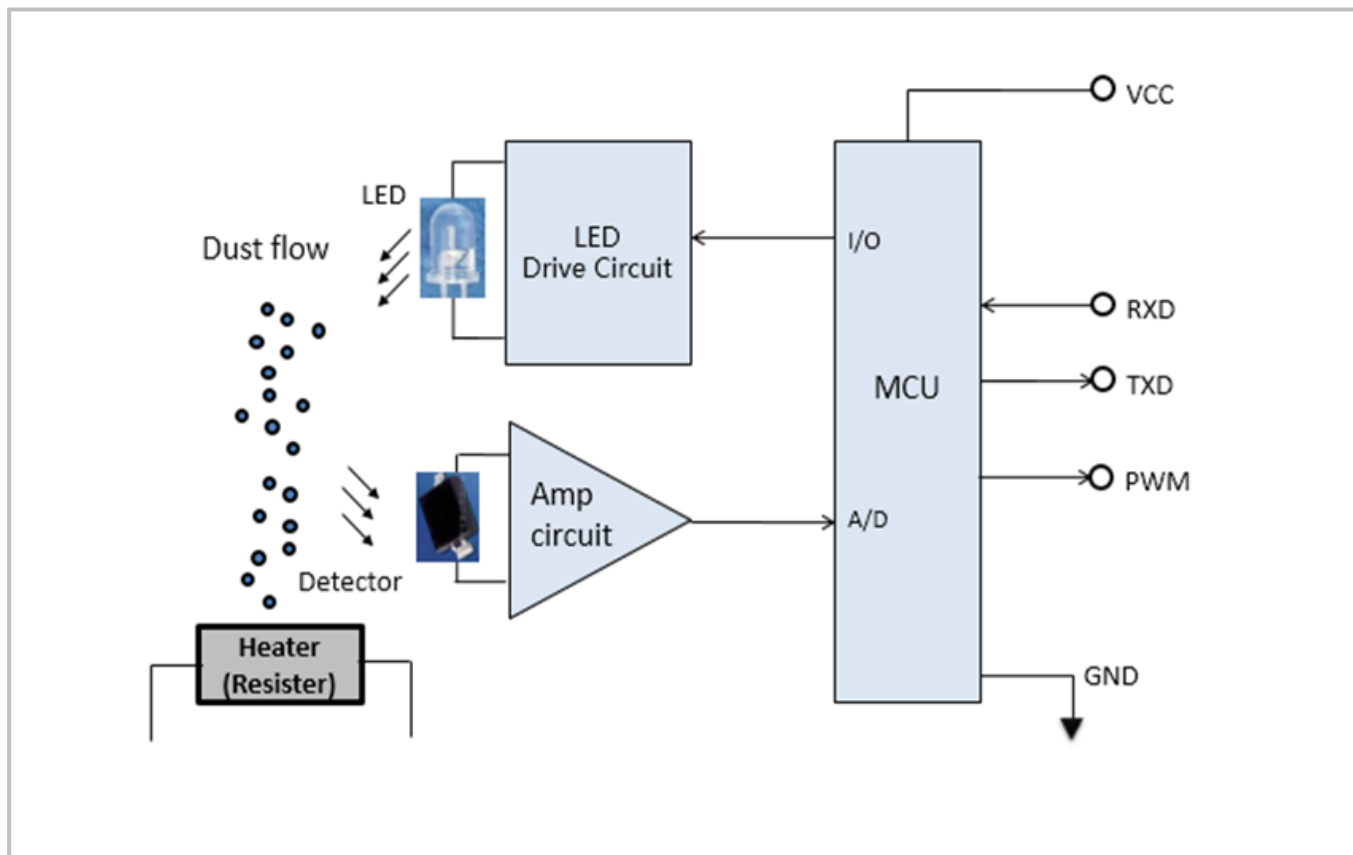

According to the above diagram, the light source part of the PM1003 is composed of an infrared LED that emits light for detecting particles and a driving circuit. The detecting part is composed of an amplifying circuit and photosensitive component that receives reflected light.

When the heating resistor heats up to generate an updraft, the particles will pass through the detection chamber. According to the scattering principle of light, the LED light generates reflected light when meet particles. Reflected light will be detected by photosensitive components. Photosensitive components will output high level when do not detect particles. Otherwise, output low pulse when detect particles. And pulse signal is in proportion on the detected light intensity. Pulse signal will be magnified by amplifier and calculated by MCU, output measuring result finally.

Dimensions and Connector

1. Dimensions (Unit mm, tolerance ± 0.2 mm)

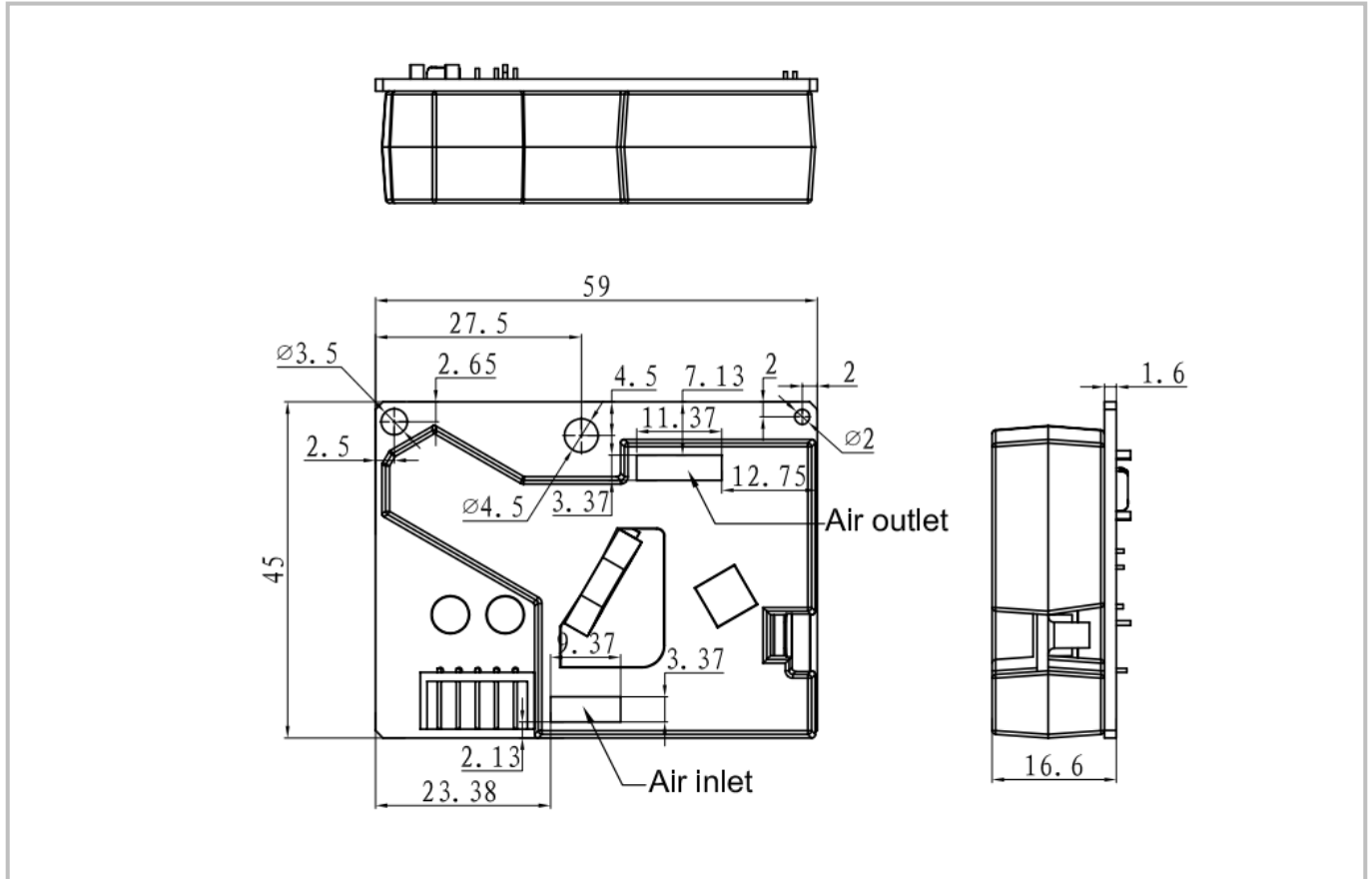

2. I/O Connector Pinout

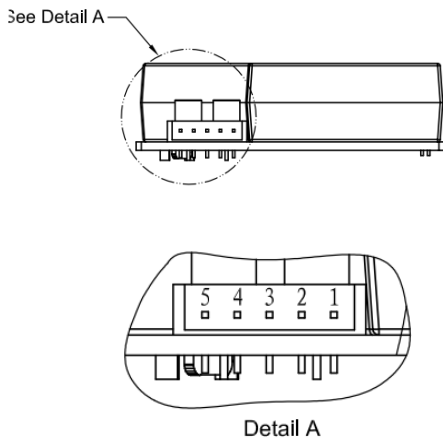

No.	Pin	Description
1	GND	Power input (ground terminal)
2	TX	UART-TX output (0-4.5V)
3	+5V	Power input (+5V)
4	P1	Pulse width output (0-4.5V)
5	RX	UART-RX input (0-4.5V)

The interface connector is located at the side of the sensor. Corresponding female plug part number is EH-5 from JST. The pitch is 2.5mm.

The connection cable with female connector at both ends can also be customized.

Photoelectric Linear

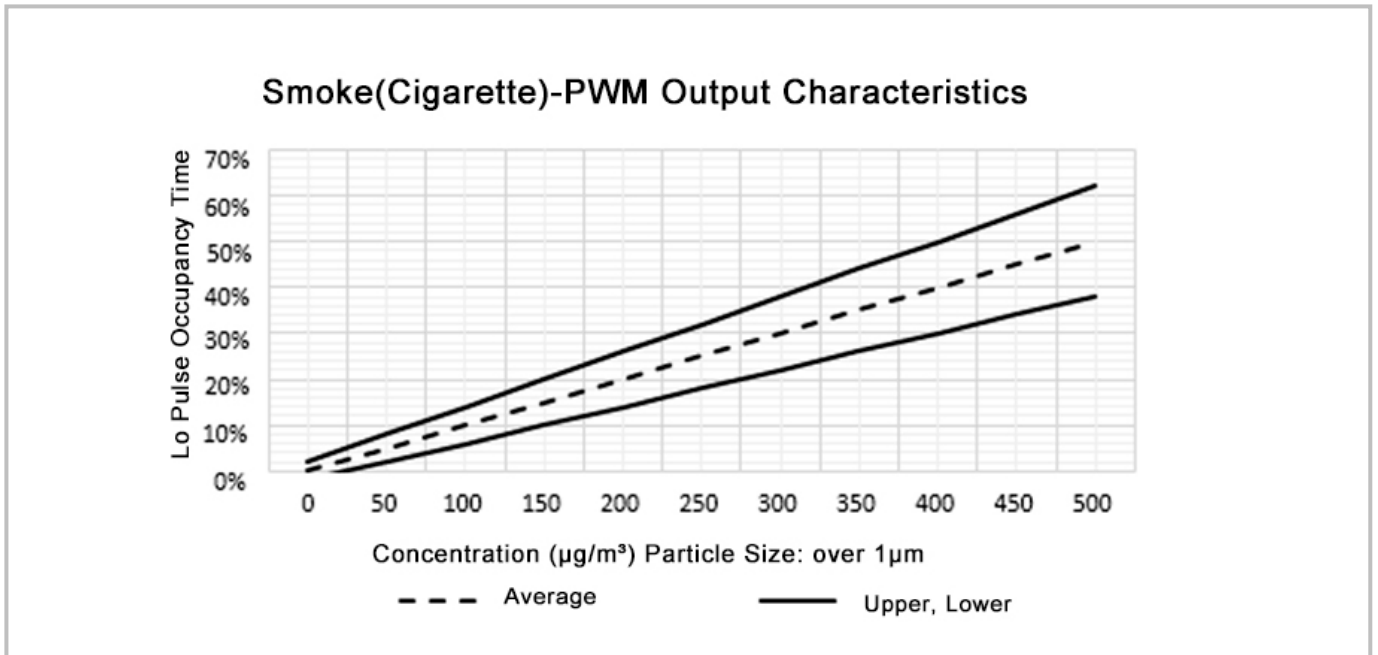

The linear curve of the sensor is verified in the following conditions:

The temperature of the environment is $25\pm 2^\circ\text{C}$

The humidity of the environment is $50\pm 10\%RH$

Cigarette smoke: Hongtashan 8mg

Communication Protocol

◆PWM communication:

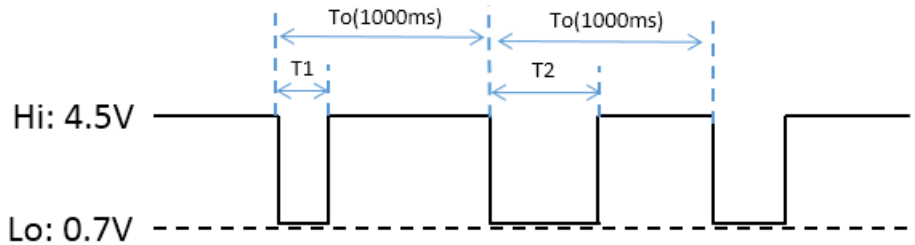

PWM Communication Description:

- The relations between low pulse time and dust concentration: $1\text{ms}=1\mu\text{g}/\text{m}^3$
- PWM cycle: 1000ms ($\pm 0.5\%$ error)
- Low level duty ratio: low pulse time T_n /PWM cycle to (1000ms)
- The sensor will output PWM signal after powered on

◆UART Communication

UART level range

- UART RX: 0~4.5V data input
- UART TX: 0~4.5V data output

UART configuration

- data bit: 8
- Stop bit: 1
- Check bit: non
- Baud rate: 9600bps

Read Measures Result of Particles:

Send: 11 02 0B 01 E1

Response: 16 11 0B DF1-DF4 DF5-DF8 DF9-DF12 DF13 DF14 DF15 DF16 [CS]

Note: $\text{PM}_{2.5} (\mu\text{g}/\text{m}^3) = \text{DF3} * 256 + \text{DF4}$ (You should change the HEX to Decimal)

Product Installation

Ensure the sensor is installed vertically (error $\leq \pm 3^\circ$). Let the air inlet be at the bottom and the air outlet at the top. When the thermistor is heated, the surrounding hot air naturally flows from the bottom to the top. The external gas enters the sensor from the air inlet and exits the air outlet to form a cycle.

Recommended Installation

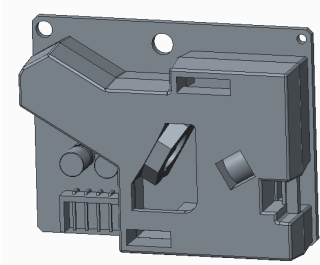

Non Recommended Installation

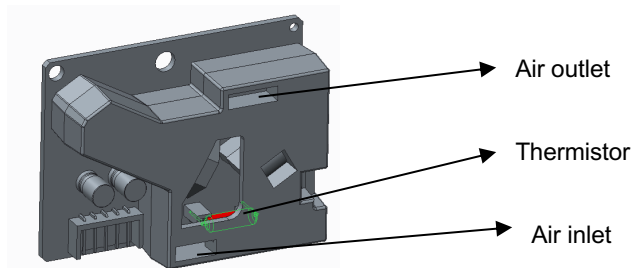
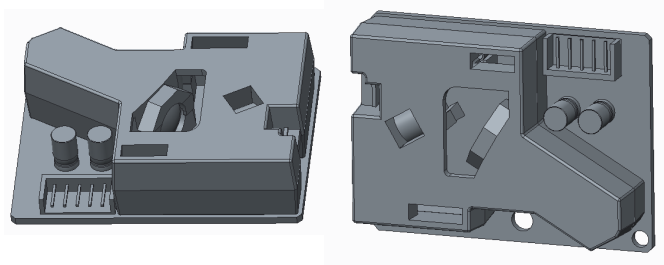

User Attention

- The best installation way is to make the surface of air inlet and outlet of the sensor clings to the air vent in the inner wall of the user device that communicate with the outside. If it's not possible, then an air isolation structure between air inlet and air outlet is necessary to avoid the air back flow in the user's device.
 - Air vent size on the internal wall of user's device for airflow should be bigger than the size of air inlet of the sensor.
 - For purification products, sensor cannot be installed in the purifying air duct. If it's not possible, it's necessary to design a separate structure for sensor installation to isolate the sensor from air purifier duct.
 - For purifier and detector device, the sensor should be installed above 20cm higher than floor to avoid contamination of large dust particles or even flocs near the ground entering the sensor, which influences the measurement of the sensor.
 - Sensor should be prohibited from using for outdoor inspection equipment. Dust storms, rain, snow, and willow flocs can have a significant impact on unprotected sensors.
 - Sensor is a complete unit. Disassembling the cover may cause irreversible damage.
- It is for household electronics products. For application of medical, mining, disaster preparedness, which needs high security and high dependence, this sensor is not suitable.
- Avoid using the sensor under the condition with strong magnetic, such as situation close to stereo speaker, microwave oven, induction cooking.
 - There is no high pressure transient protection circuit of the sensor. The power supply of the sensor should be stable and low noise. Please refer to the working voltage in specification table.

Packing Information

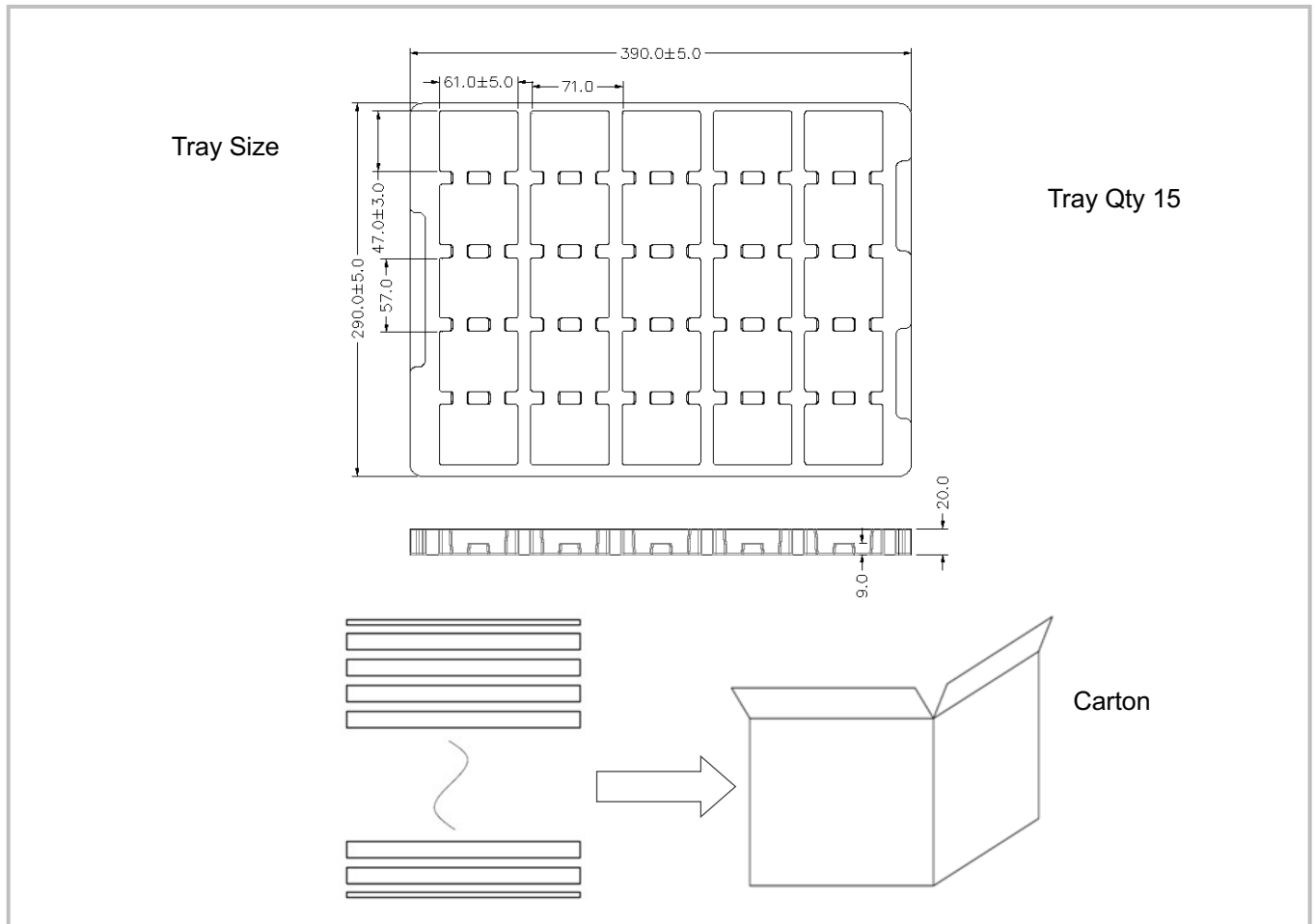

Sensor per Tray	Tray per Carton	Sensor Per Carton	Carton Dimensions	Packing Material
25 pcs	15 layers	375 pcs	395*310*330 mm	Blister Tray

After-Sales Services and Consultancy

Wuhan Cubic Optoelectronics Co., Ltd.

Tel: +86 (0)27 81628827 Fax: +86 (0)27 81628821

Add: Fenghuang No.3 Road, Fenghuang Industrial Park, Eastlake Hi-tech Development Zone, Wuhan 430205, China

E-mail: info@gassensor.com.cn